

MECHANICAL PARAMETERS	UNITS	
FRAME SIZE	-	C
MASS	lbf [kg]	0.45 [.21]
ROTOR INERTIA	oz-in-sec ² x 10 ⁻³ [g-cm ²]	0.038 [2.71]
OPERATING TEMPERATURE RANGE	°C	-60 TO +200
MOTOR PARAMETERS		
DRIVE TYPE	-	2 PHASE - BIPOLAR
PHASES	#	2
REDUNDANCY	-	SIMPLEX
FULL STEP SIZE ⁵	DEGREES/SEC [RADIANS/SEC]	0.83 [0.014]
NO LOAD RESPONSE RATE ^{1,2,5}	PULSES/SEC	326
	DEGREES/SEC [RADIANS/SEC]	271 [4.72]
TORQUE AT LOW PULSE RATE ^{1,5}	lbf-in [N-m]	4.05 [0.45]
POWERED HOLDING TORQUE ^{1,5}	lbf-in [N-m]	5.73 [0.65]
UNPOWERED HOLDING ⁵	lbf-in [N-m]	1.2 [0.135]
RESISTANCE ³	Ohms	144 - 176
INDUCTANCE ³	mH	42
MAXIMUM WINDING TEMPERATURE	°C	200
GEARBOX PARAMETERS		
GEARBOX TYPE	-	PLANETARY
GEAR REDUCTION	-	36:1
NUMBER OF STAGES	-	2
TYPICAL MECHANICAL EFFICIENCY ^{1,4}	%	81
TYPICAL BACKLASH	DEGREES	1

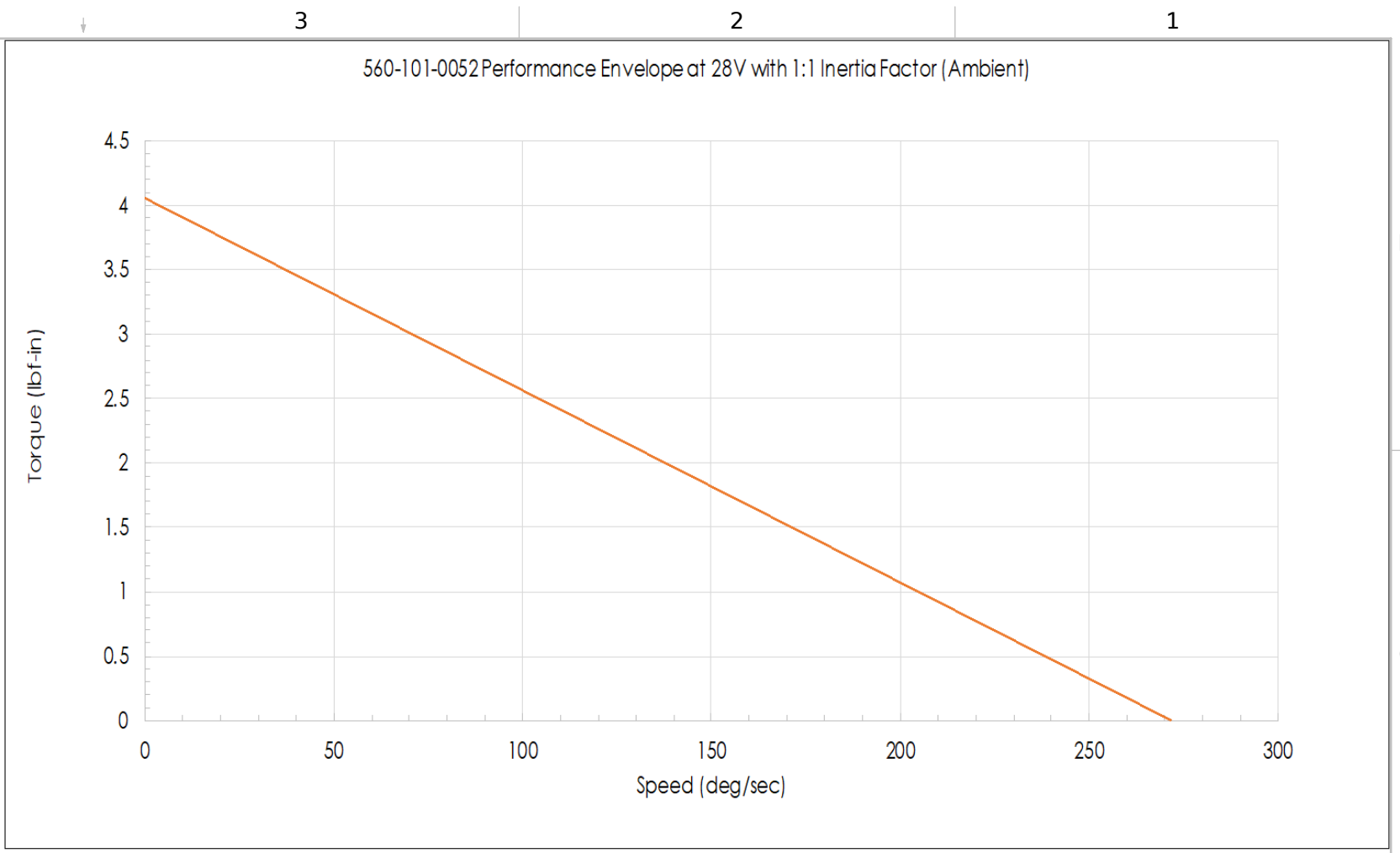

- NOTES:
1. ASSUMING 28 VDC BUS VOLTAGE AT 22°C, FULL STEP MODE
 2. ASSUMING 1:1 INERTIA FACTOR (DRIVEN INERTIA/ROTOR INERTIA). CONTACT HBR FOR INERTIA FACTORED RESPONSE RATE PER PHASE.
 3. PER PHASE.
 4. COMBINED STAGES
 5. AT THE ACTUATOR OUTPUT (MOTOR + GEARBOX)
 6. STANDARD OUTPUT SHAFT GEOMETRY. CONTACT HONEYBEE ROBOTICS FOR FURTHER OPTIONS.
 7. STEP FILE ATTACHED TO PDF.

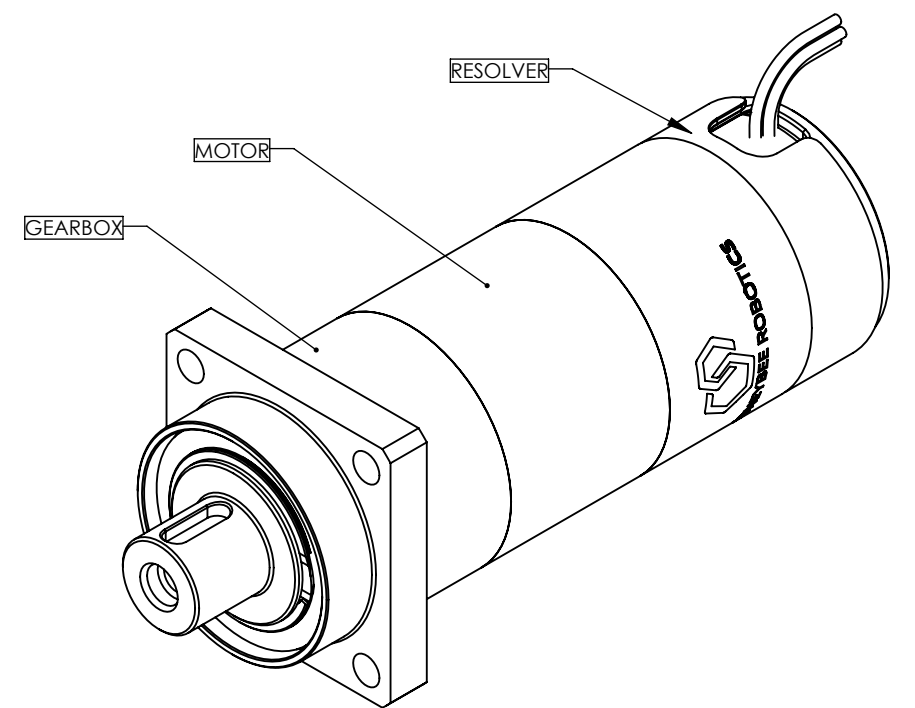
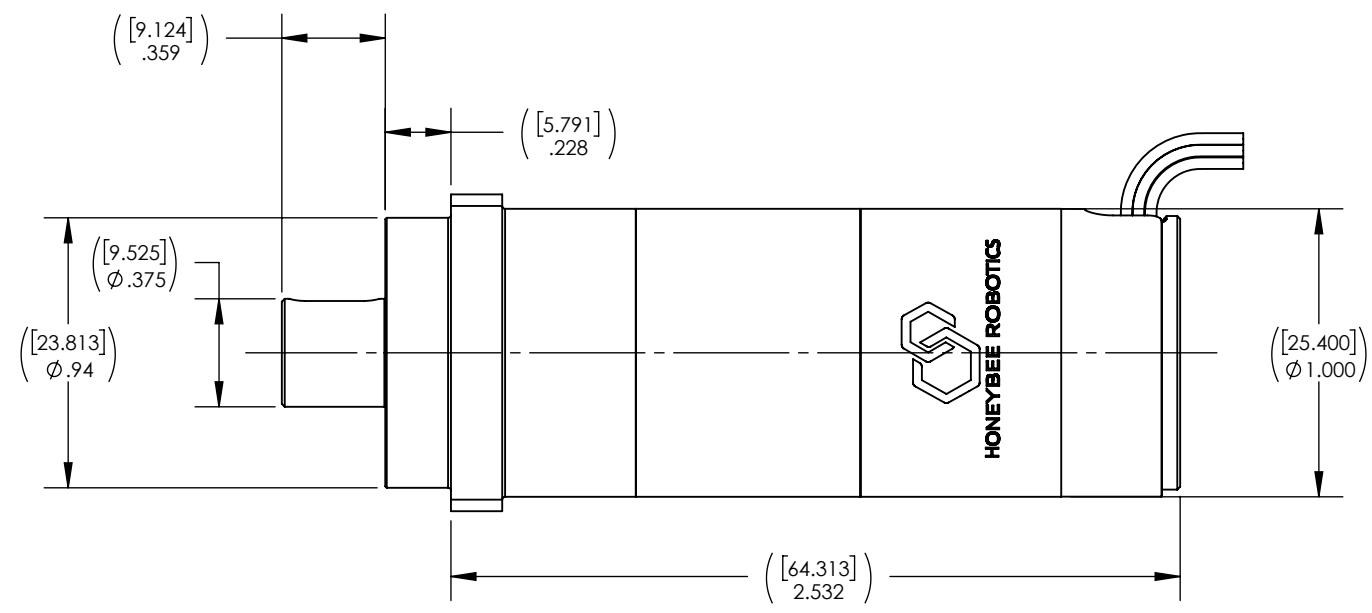
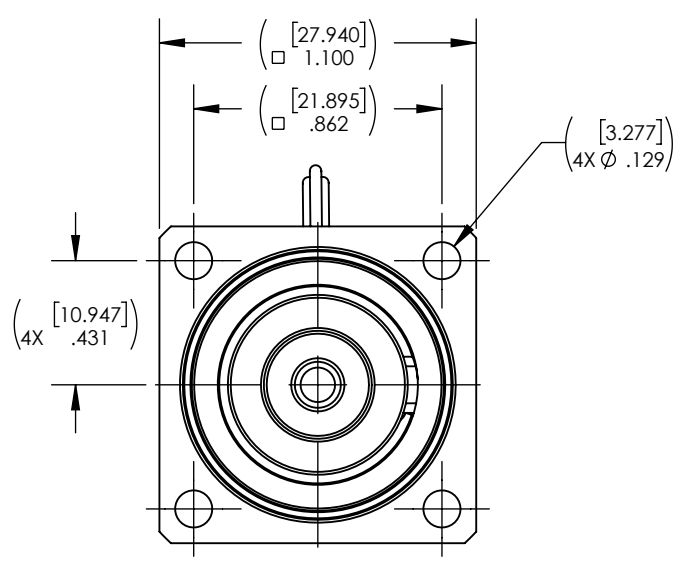

UNLESS OTHERWISE NOTED: DIMENSIONS ARE IN INCHES <small>(CRITICAL DIMENSION)</small>		 HONEYBEE ROBOTICS	PROJECT TITLE STANDARD PRODUCT DATA SHEETS
<small>(ALL FEATURE CONTROL FRAME)</small> INTERPRET DRAWING PER ASME Y14.5-2018 LINEAR TOLERANCES: .X ±.05 SURFACE .XX ±.01 ROUGHNESS .XXX ±.005 (XXX) CRITICAL ANGULAR TOLERANCES: ±0.5 DEGREES			
MICROINCHES OR BETTER 		PART DESCRIPTION C-SIZE STEPPER, 2-PHASE, 36:1	REVISION A
CAGE CODE 8DSS5	SHEET SIZE B	SHEET 1 OF 1	